

APPLICATION: G3 FAX Interface, Serial Network Interface
Applicable models: UCH-250, UCH-100

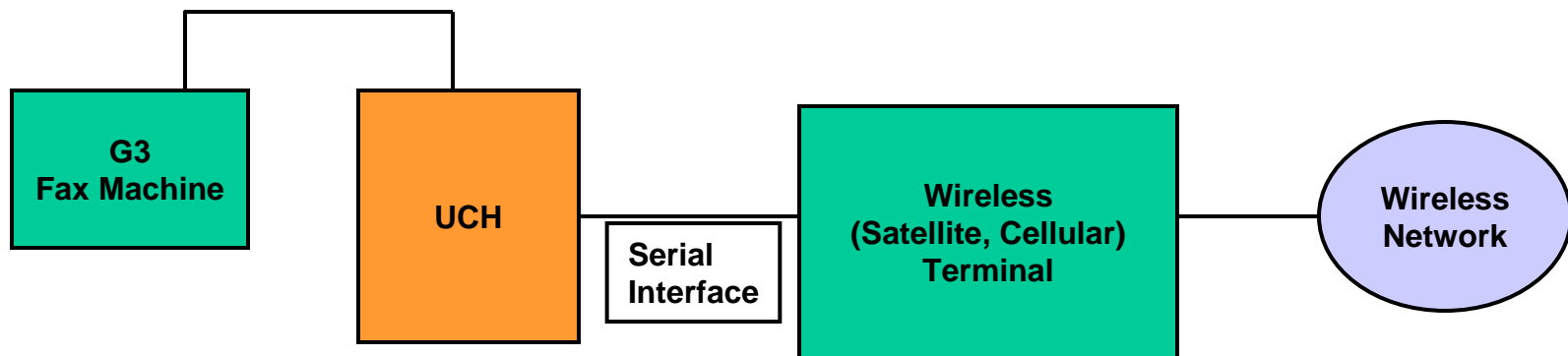

APPLICATION: Data Terminal Interface, Serial Network Interface
Applicable models: UCH-250, UCH-100

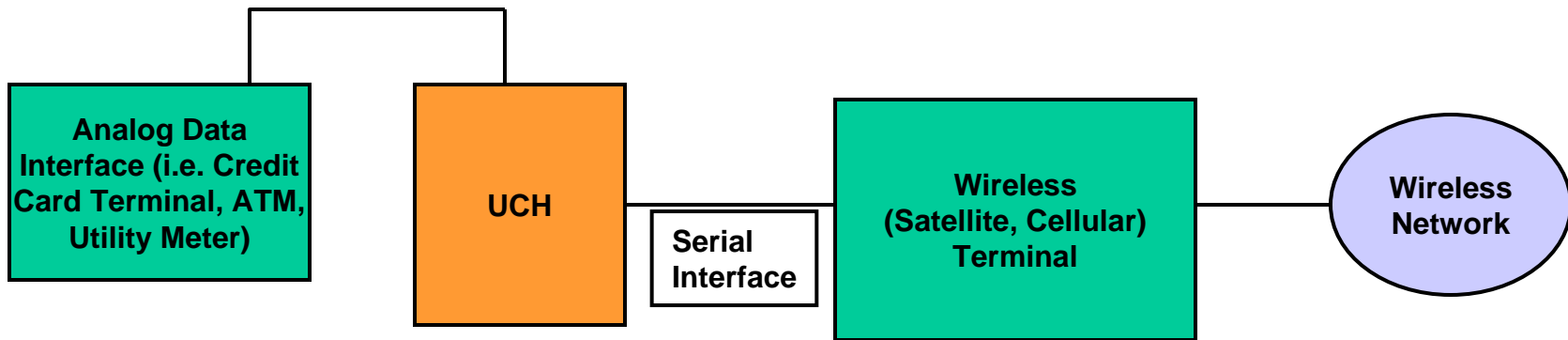

APPLICATION: G3 FAX Interface, USB Network Interface
Applicable models: UCH-250, UCH-100

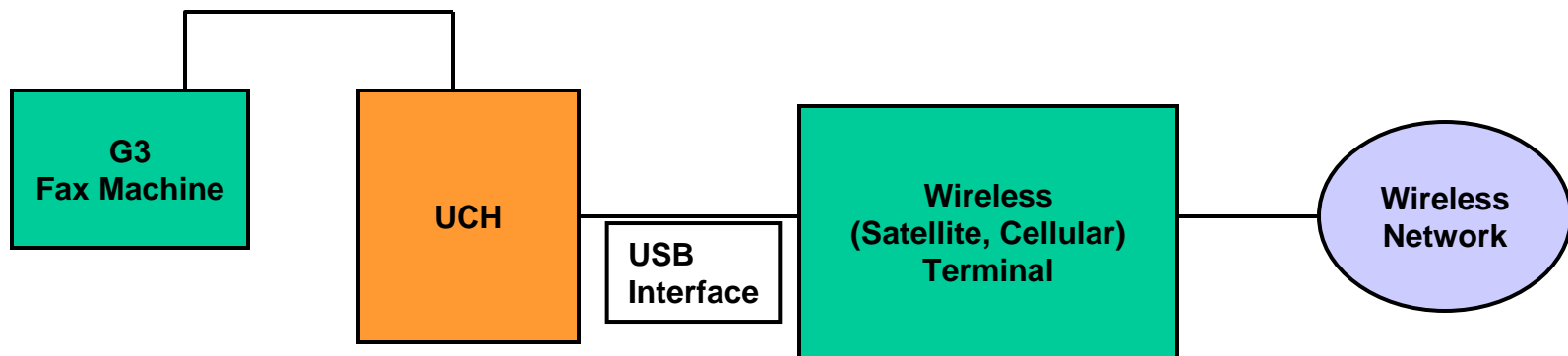

APPLICATION: Data Terminal Interface, USB Network Interface
Applicable models: UCH-250, UCH-100

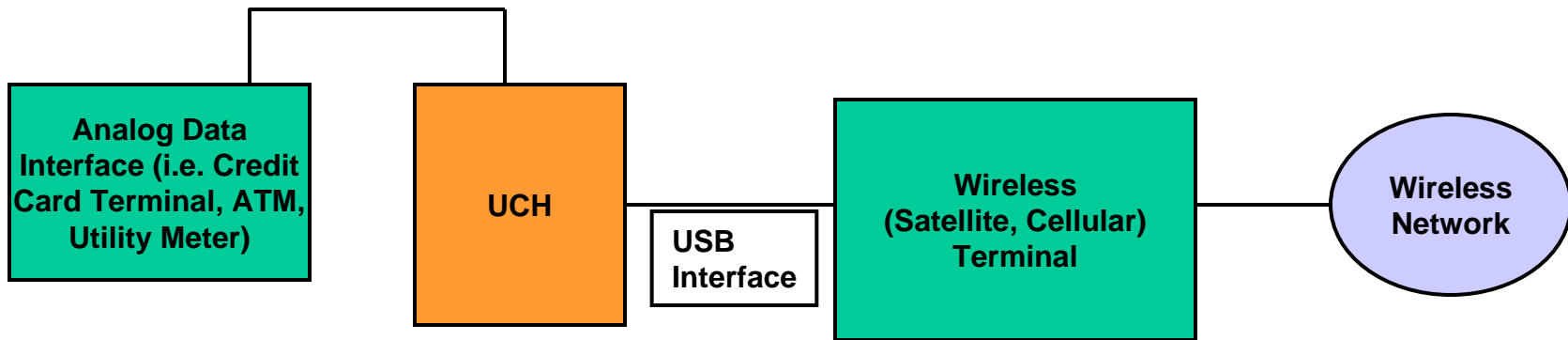

APPLICATION: G3 FAX Interface, Ethernet Network Interface
Applicable models: UCH-250

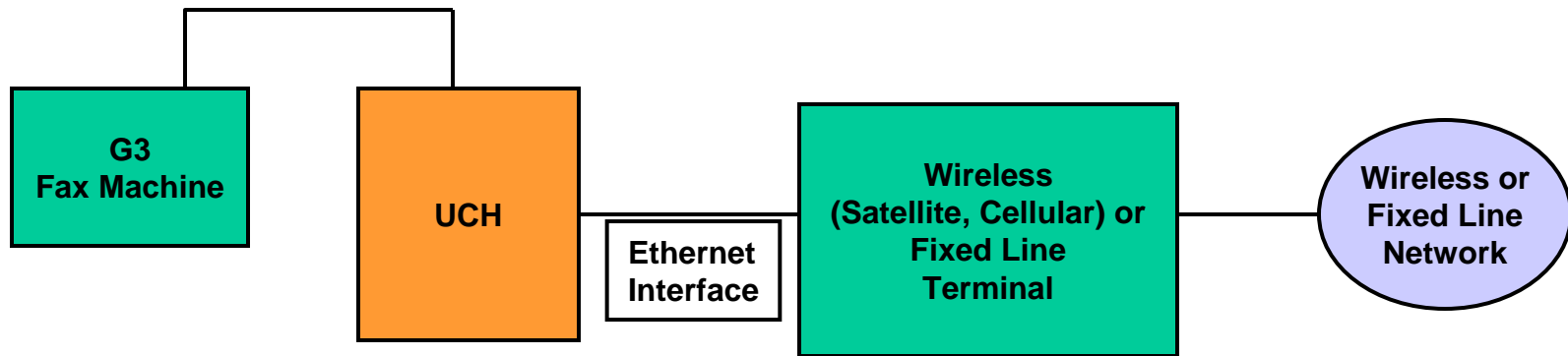

APPLICATION: Data Terminal Interface, Ethernet Network Interface
Applicable models: UCH-250

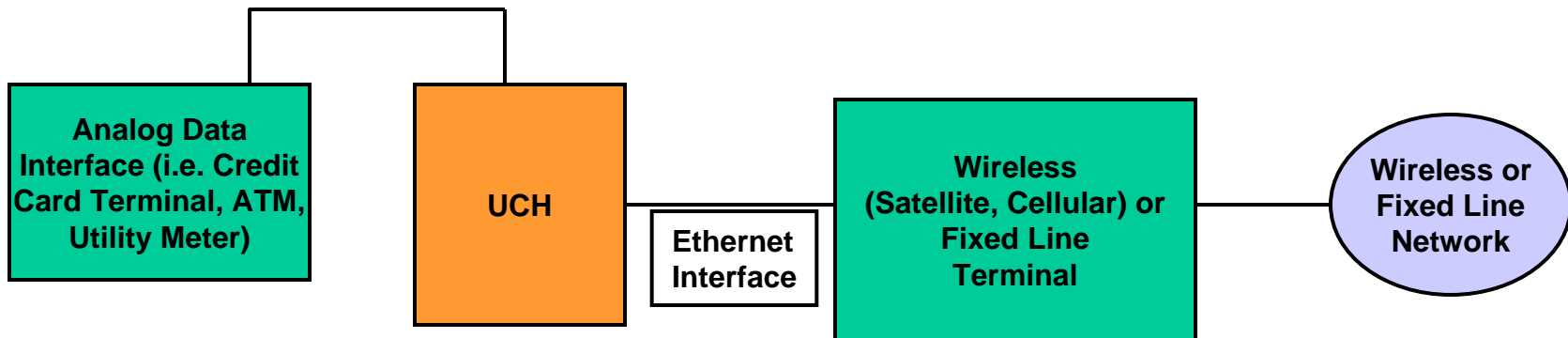

APPLICATION: G3 FAX Interface, PCCARD Network Interface
Applicable models: UCH-250

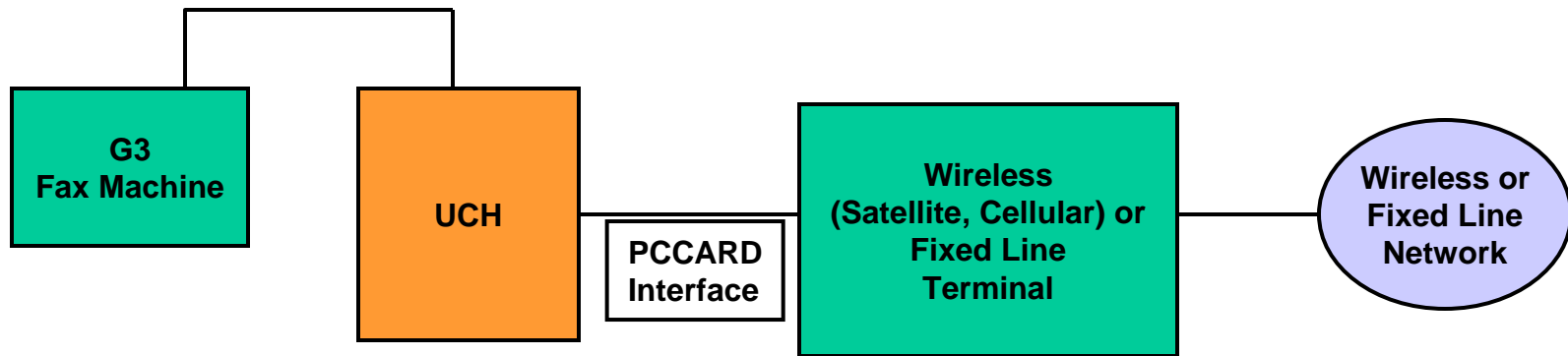

APPLICATION: Data Terminal Interface, PCCARD Network Interface
Applicable models: UCH-250

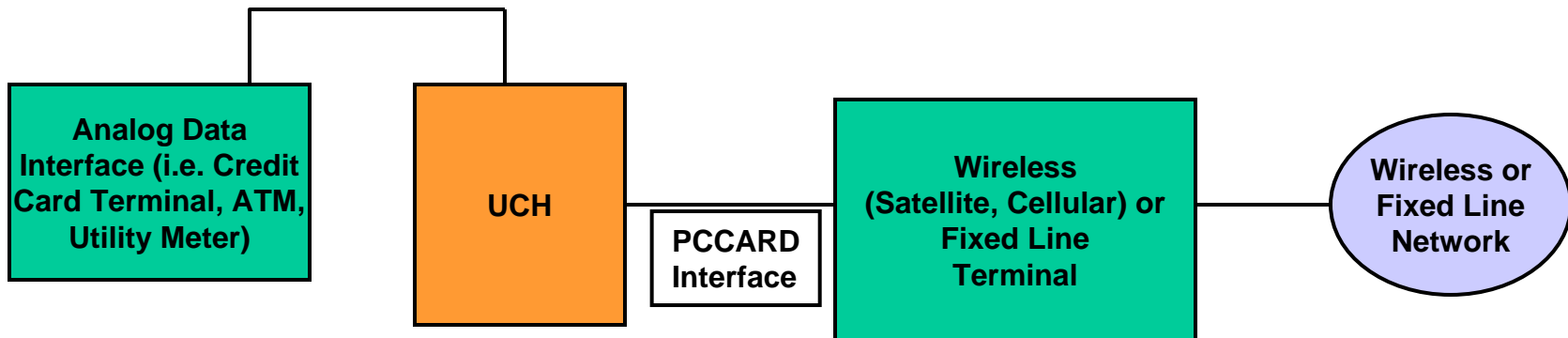

APPLICATION: USB Device Interface, Serial Network Interface
Applicable models: UCH-250

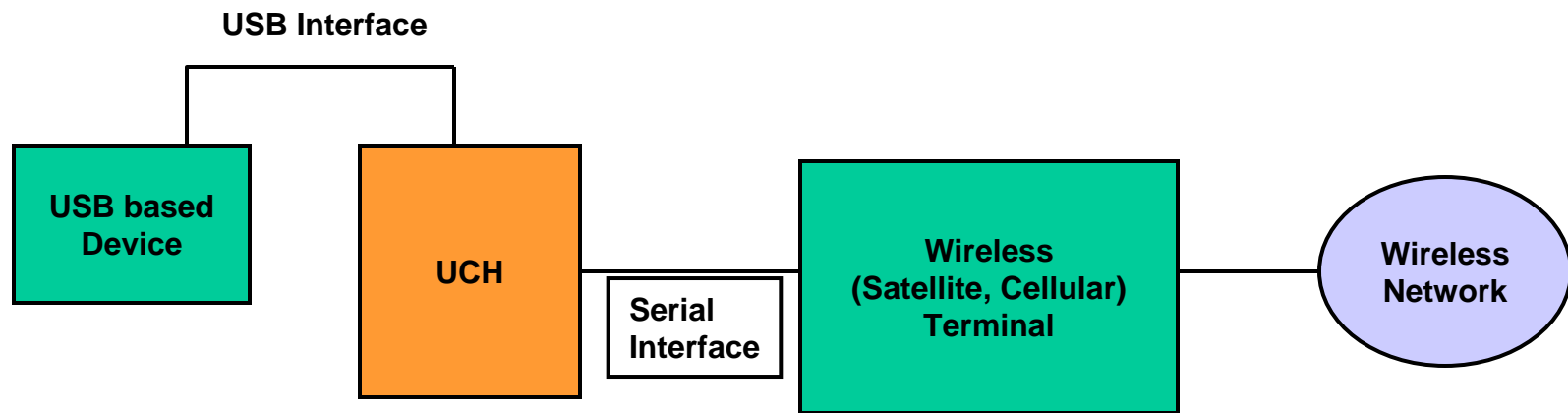

APPLICATION: USB Device Interface, Serial Network Interface
Applicable models: UCH-250

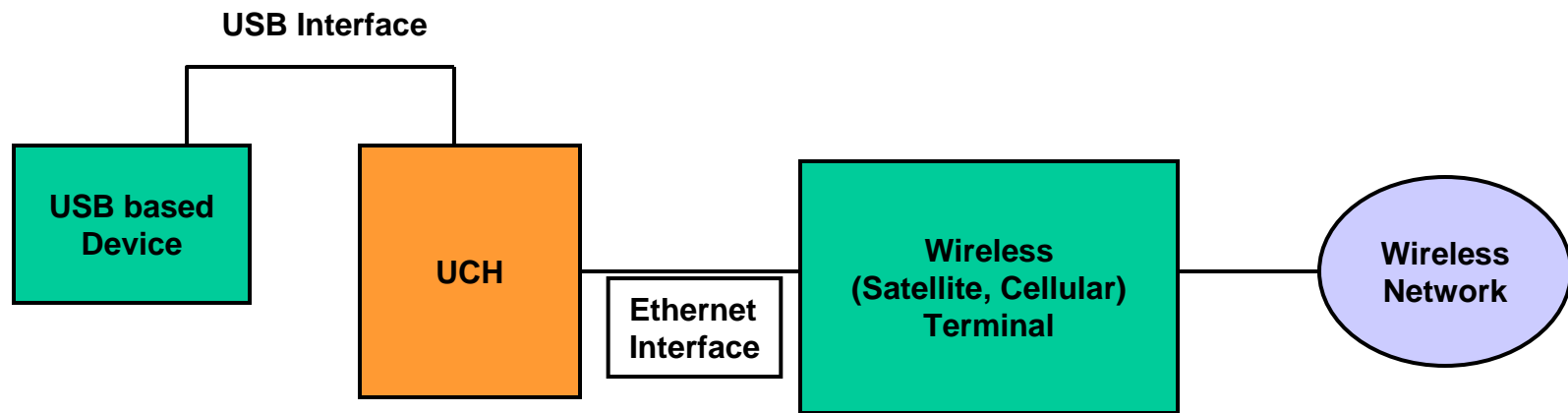

APPLICATION: PCCARD Device Interface, Serial Network Interface
Applicable models: UCH-250

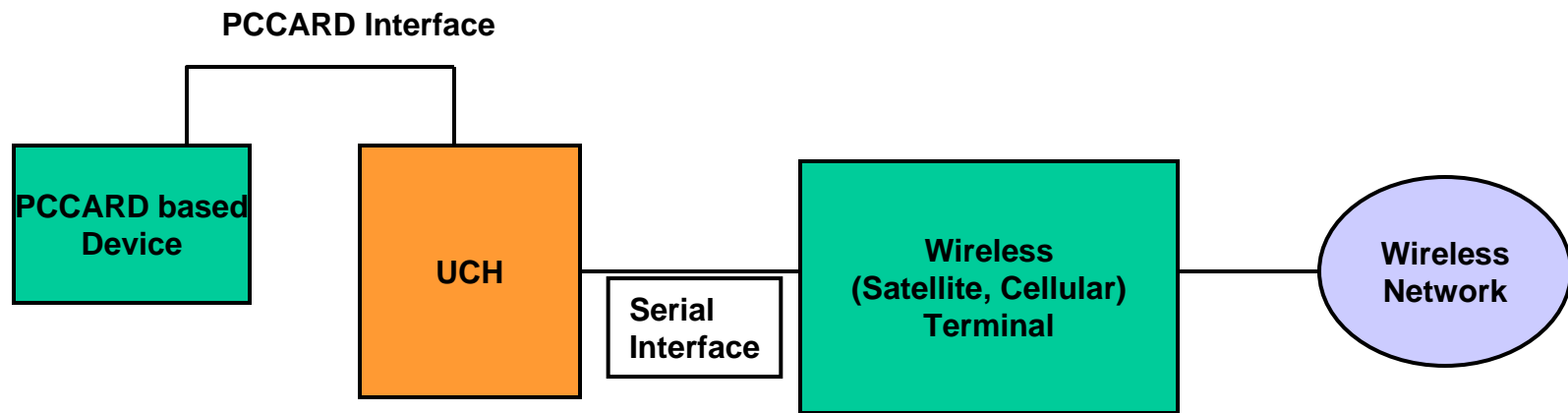

APPLICATION: PCCARD Device Interface, Serial Network Interface
Applicable models: UCH-250

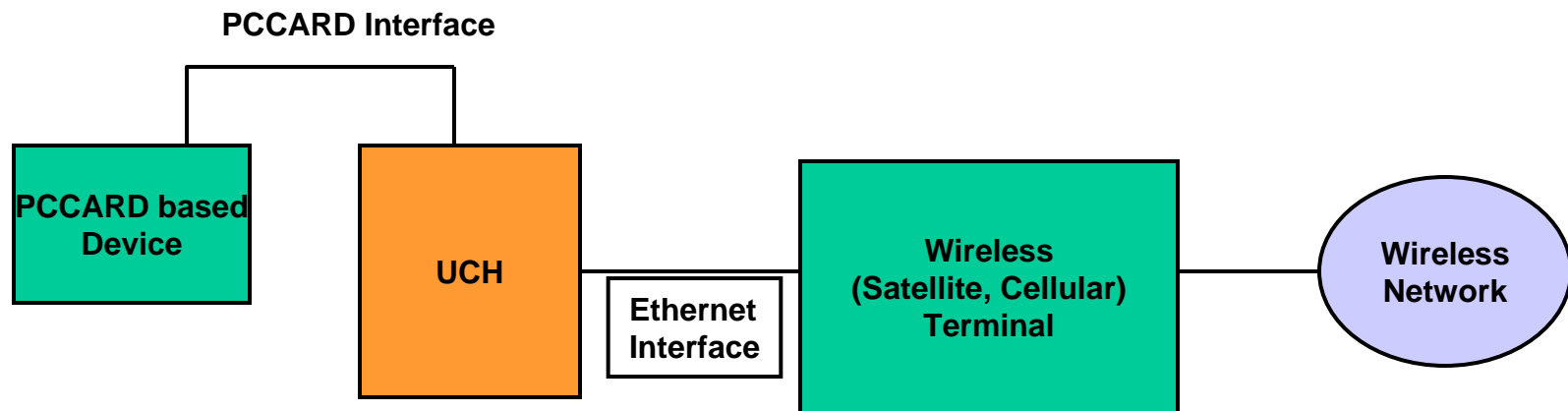

APPLICATION: Ethernet Routing, Serial Network Interface
Applicable models: UCH-250

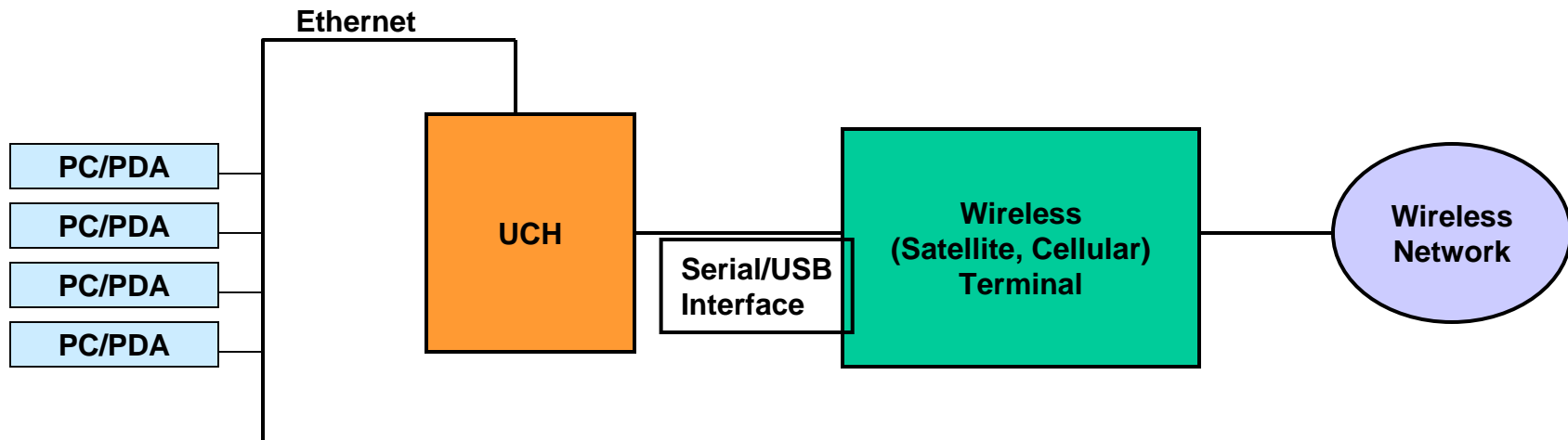

APPLICATION: WiFi Routing, Serial Network Interface
Applicable models: UCH-250

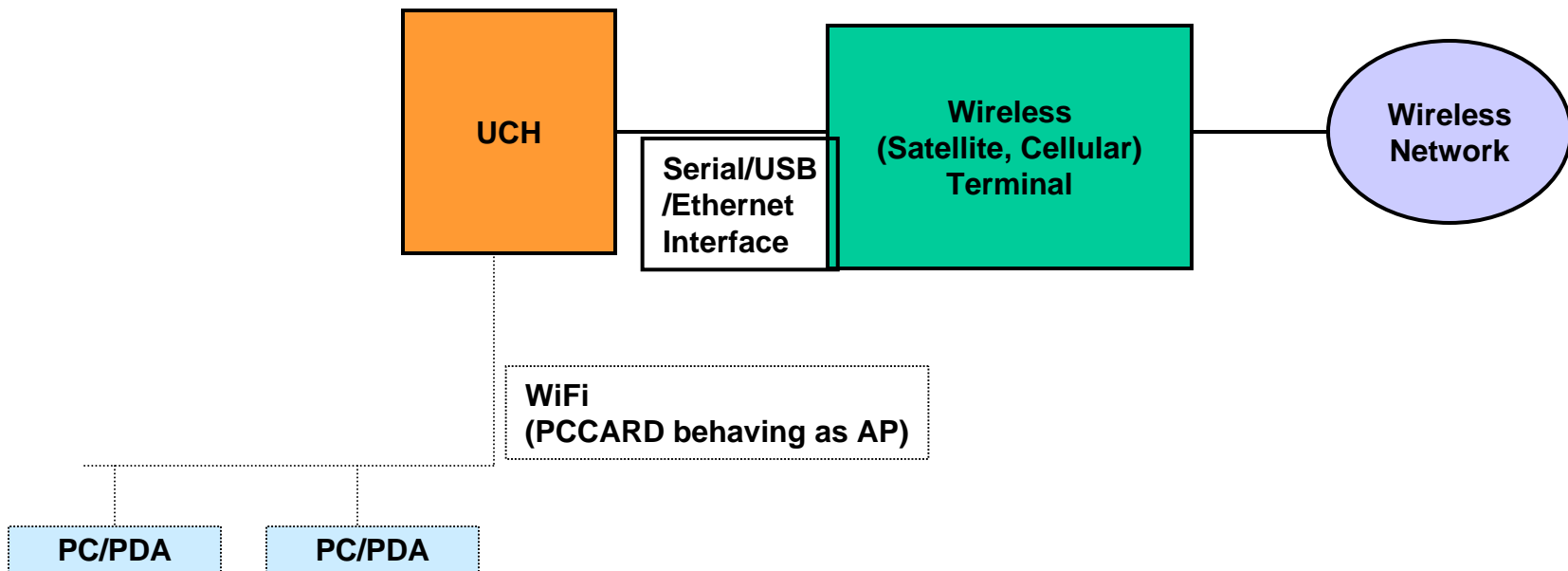

APPLICATION: Bluetooth devices / subnetworking, Applicable models: UCH-250

